



# Carbon Rotary Potentiometers - 16 mm size

Dust-proof

Plastic Case

Types

CIP160TZC

P160TZC

## Mechanical data

Rotation angle:  $270^\circ \pm 5^\circ$   
 Operating torque:  $0.4 \div 1.5$  Ncm  
 Permissible torque at end stop: 60 Ncm max  
 Permissible axial spindle load: 100 N  
 (5 sec max)  
 Life:  $\geq 15.000$  cycles  
 Weight, std spindle:  $\sim 13$  g

## Optional feature

• Rotation angle  $300^\circ \pm 5^\circ$ :  
 Types **CIP162TZC** and **P162TZC**.

## Resin compounding-proof

These potentiometers - except the bush and spindle - can be dipped into the usual insulating resin compounding.

## Electrical data

Rated dissipation @  $40^\circ\text{C}$ : 0.25 W linear law  
 0.12 W non-linear law  
 Limiting element voltage: 350 VDC  
 Insulation resistance:  $\geq 5$  G $\Omega$   
 Insulation voltage: 500 VAC  
 Rated resistance: E3 Series; optional E6 Series  
 • linear law: 100R to 4M7  
 • non-linear law: 1K0 to 2M2  
 Tolerance on rated resistance:  
 • 100R to 1M0:  $\pm 20\%$   
 • over 1M0:  $\pm 30\%$   
 • optional (1K0 to 1M0):  $\pm 10\%$   
 Resistance law: A, B, C, F, S, T, X

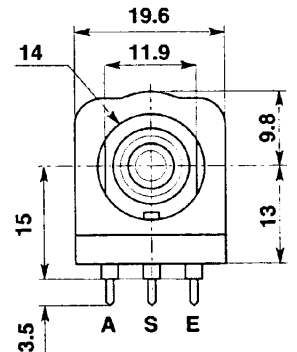
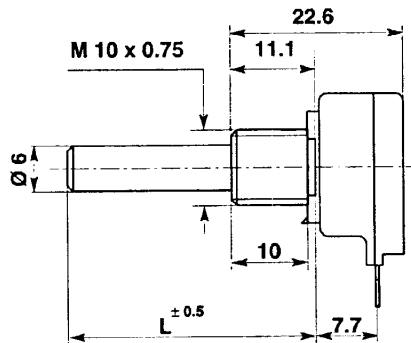
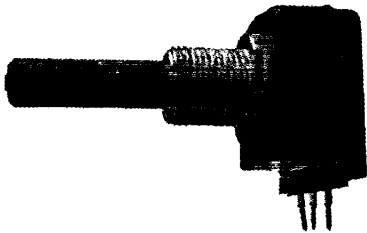

## CIP16TZC

viewed on  
component side

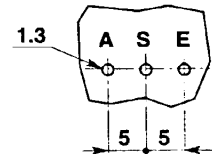

## Types

<b>CIP160TZC</b>	P.c. terminations
<b>P160TZC</b>	Solder tag terminations

## Standard spindle

L = 50 mm, plastic, F1 type

## Spindle variations

Available types	
Plastic spindle	Metal spindle
F1, F2, F3, F4, F5, F6, F10, F11, F12	M1, M2, M3, M4, M 10, M11, M12

Chassis piercing  
2 possibilities

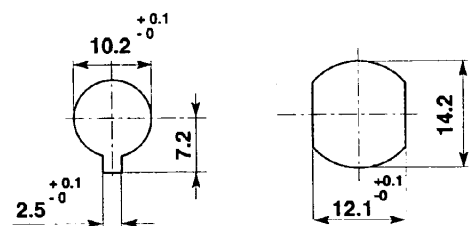

Spindle details: see p. 81 - 82.

Normalised spindles: see p. 84.



# Carbon Rotary Potentiometers - 16 mm size

Spindle variations - 6 mm diameter	Available types	
	Plastic	Metal
<p><math>D = 6^{+0.01}_{-0.075}</math></p> <p>Mounting face</p> <p><math>L \pm 0.5</math></p> <p>L = 15 to 60</p>	F1	M1
<p><math>D = 6^{+0.01}_{-0.075}</math></p> <p>12</p> <p>4 <math>^{-0.1}</math></p> <p><math>L \pm 0.5</math></p> <p>spindle in full CCW position</p> <p>205°</p> <p>Optional 210° Optional 225°</p> <p>standard</p> <p>L = 15 to 60</p>	F2	M2
<p><math>D = 6^{+0.01}_{-0.075}</math></p> <p>A</p> <p>5 <math>^{+0.03}_{-0.05}</math></p> <p><math>L \pm 0.5</math></p> <p>spindle in full CCW position</p> <p>205°</p> <p>Optional 210° Optional 225°</p> <p>standard</p> <p>A = 15 - L = 20 to 60 A = 10 - L = 15 to 60</p>	F3 A = 15	M3 A = 15
	F4 A = 10	M4 A = 10
<p><math>D = 6^{+0.01}_{-0.075}</math></p> <p>A</p> <p>4.6 <math>^{+0.03}_{-0.05}</math></p> <p><math>L \pm 0.5</math></p> <p>spindle in full CCW position</p> <p>205°</p> <p>A = 10 - L = 15 to 60 A = 15 - L = 20 to 60 A = 20 - L = 25 to 60</p>	F10 A = 10	M10 A = 10
	F11 A = 15	M11 A = 15
	F12 A = 20	M12 A = 20

The orientation of the flat indicated in the drawings is for plastic spindles only. The optional orientations of 210° and 225° place the flat in horizontal position (zero degrees) at half of rotation angle, respectively in potentiometers with 300° and 270° of rotation angle.

For metal spindles, unless specified in the order, the orientation of the flat may change in each potentiometer.



# Carbon Rotary Potentiometers - 16 mm size

Spindle variations - 6 mm diameter		Available types	
		Plastic	Metal
<p>Mounting face</p> <p>slot 3.5 x 1.2</p> <p>D = 6</p> <p>L ± 0.5</p> <p>A ± 1</p>	<p>100°</p> <p>20°</p> <p>Ø 5</p> <p>D = 6</p> <p>18 Teeth</p>	F5	NOT
		<p>90°</p> <p>15°</p> <p>Ø 5.4</p> <p>D = 6</p> <p>24 Teeth</p>	F6
<p>A = 10 or 6      L = 10 to 60</p>			
<p>1.6</p> <p>D = 6</p> <p>M7 x 0.75</p> <p>Ø 5.06</p> <p>2</p> <p>A</p> <p>L ± 0.5</p> <p>18 teeth</p>	<p>225°</p> <p>90°</p> <p>D = 6</p> <p>spindle in full CCW position</p> <p>210° for P162 types</p>	F31	M31
		A = 7.5	A = 7.5
<p>A = 7,5    L = 15* to 25 A = 12,5    L = 20* to 30</p>		F32	M32
<p>A = 12.5</p>		A = 12.5	
<p>D = 6</p> <p>A</p> <p>2.5</p> <p>M7 x 0.75</p> <p>L ± 0.5</p> <p>40 teeth</p>	<p>225°</p> <p>45°</p> <p>D = 6</p> <p>spindle in full CCW position</p> <p>210° for P162 types</p>	F33	M33
		A = 7	A = 7
<p>A = 7    L = 15* to 25 A = 12    L = 20* to 30</p>		F34	M34
<p>A = 12</p>		A = 12	
<p>D = 6</p> <p>A</p> <p>2</p> <p>M7 x 0.75</p> <p>L ± 0.5</p> <p>40 teeth</p>	<p>Index</p> <p>45°</p> <p>D = 6</p> <p>spindle in full CCW position</p> <p>30° for P162 types</p>	F35	M35
		L = 20* to 30	

\* Bush lengths: 4,5 mm or 5 mm.

Available spindles are specified on the pages describing each potentiometer type.



# Carbon Rotary Potentiometers - 16 mm size

## Normalised plastic spindles

Standard types & lengths

Potentiometer types	D mm	Spindle types	Normalised lengths - mm									
			15	18	20	22	25	30	32	40	60	
(CI) P160C	4	<b>F21</b> - F22-F23	15	18	20	22	25	30	32	40	60	
CI P161C	6	F31-F32-F33-F34-F35-F1-F6	<sup>(2)</sup> 15	20	25	30						
P160BA	6	<b>F1</b> - F3-F6	<sup>(1)</sup> 20	22	25	30	40	50				
(CI) JP16C	4	<b>F21</b> - F22-F23	15	18	20	22	25	30	32	40	60	
	6	F31-F32-F33-F34-F35-F1-F6	<sup>(2)</sup> 15	20	25	30						
(CI) PC160C IL/2IL EP160C IL/2IL P161EC IL/2IL	4	<b>F21</b> - F22-F23	15	18	20	22	25	30	32	40	60	
	6	F31-F32-F33-F34-F35-F1-F6	<sup>(2)</sup> 15	20	25	30						
P160 IBA	6	<b>F1</b> - F3-F6	<sup>(1)</sup> 20	22	25	30	40	50				
(CI) P160KC	4	F21-F22-F23	15	18	20	22	25	30	40			
	6	<b>F1</b> -F6	15	18	20	22	25	30	40	50	60	
EP160Z-EPP160Z	6	<b>F1</b> -F6	21	26	29	31	33	36	41	51	61	
EP160KC EPP160KC P160EKC	6	<b>F1</b> -F6	10	15	18	20	22	25	30	40	50	60
P160ZCS	4	F21-F22-F23	15	18	20	22	25	30	40			
	6	<b>F1</b> -F6	15	18	20	22	25	30	40	50	60	
SP160Z	6	<b>F1</b> -F6	21.5	24.5	26.5	28.5	31.5	36.5	46.5	50		
EP160KC IPP CI P160KC IPP	4	F21- <b>F22</b> -F23	15	18.5	20.5	22	25	30	40			
CI P160KC IP (CI) JP160KC	4	F21-F22-F23	15	18	20	22	25	30	40			
	6	<b>F1</b> -F6	15	18	20	22	25	30	40	50	60	
(CI) TJP160KC (CI) QJP160KC	6	<b>F1</b> -F6	10	15	18	20	22	25	30	35	50	60
(CI) P160TZC	6	<b>F1</b> -F6	16	19	21	23	26	31	41	50		

(1) F6 type only

(2) F31 and F33 types only

F22-F23 types: with flat in standard position

## Normalised metal spindles

(CI) P160C	4	M21	13	15	17	20	25					
(CI) JP16C	4	M22 flat 90°	13	15	17							
(CI) P160KC	4	M22 flat 225°	13	15	17	20	25					
(CI) JP160KC	4	M23 flat 90°	18	20	22	25	30					
(CI) P160C IL/2IL	6	M31-M33	15	17								
(CI) P160KC IP	6	M32-M34-M35	20	22	25	30						