

Features

- Synchronous Counting and Asynchronous Loading
- Two Outputs for N-Bit Cascading
- Look-Ahead Carry for High-Speed Counting
- Fanout (Over Temperature Range)
 - Standard Outputs 10 LSTTL Loads
 - Bus Driver Outputs 15 LSTTL Loads
- Wide Operating Temperature Range . . . -55°C to 125°C
- Balanced Propagation Delay and Transition Times
- Significant Power Reduction Compared to LSTTL Logic ICs
- HC Types
 - 2V to 6V Operation
 - High Noise Immunity: $N_{IL} = 30\%$, $N_{IH} = 30\%$ of V_{CC} at $V_{CC} = 5V$
- HCT Types
 - 4.5V to 5.5V Operation
 - Direct LSTTL Input Logic Compatibility, $V_{IL} = 0.8V$ (Max), $V_{IH} = 2V$ (Min)
 - CMOS Input Compatibility, $I_I \leq 1\mu A$ at V_{OL} , V_{OH}

Description

The 'HC192, 'HC193 and 'HCT193 are asynchronously presettable BCD Decade and Binary Up/Down synchronous counters, respectively.

Presetting the counter to the number on the preset data inputs (P0-P3) is accomplished by a LOW asynchronous parallel load input (\overline{PL}). The counter is incremented on the low-to-high transition of the Clock-Up input (and a high level on the Clock-Down input) and decremented on the low to high transition of the Clock-Down input (and a high level on the Clock-up input). A high level on the MR input overrides any other input to clear the counter to its zero state. The Terminal Count up (carry) goes low half a clock period before the zero count is reached and returns to a high level at the zero count. The Terminal Count Down (borrow) in the count down mode likewise goes low half a clock period before the maximum count (9 in the 192 and 15 in the 193) and returns to high at the maximum count. Cascading is effected by connecting the carry and borrow outputs of a less significant counter to the Clock-Up and Clock-Down inputs, respectively, of the next most significant counter.

If a decade counter is present to an illegal state or assumes an illegal state when power is applied, it will return to the normal sequence in one count as shown in state diagram.

Pinout

CD54HC192, CD54HC193, CD54HCT193 (CERDIP)
 CD74HC192 (PDIP, SOIC, SOP, TSSOP)
 CD74HC193 (PDIP, SOIC)
 CD74HCT193 (PDIP)
 TOP VIEW

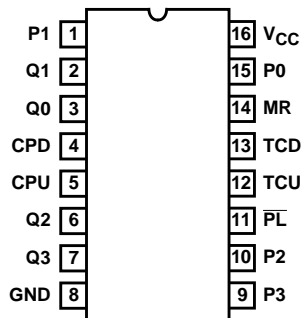

Ordering Information

PART NUMBER	TEMP. RANGE (°C)	PACKAGE
CD54HC192F3A	-55 to 125	16 Ld CERDIP
CD54HC193F3A	-55 to 125	16 Ld CERDIP
CD54HCT193F3A	-55 to 125	16 Ld CERDIP
CD74HC192E	-55 to 125	16 Ld PDIP
CD74HC192NSR	-55 to 125	16 Ld SOP
CD74HC192PW	-55 to 125	16 Ld TSSOP
CD74HC192PWR	-55 to 125	16 Ld TSSOP
CD74HC193E	-55 to 125	16 Ld PDIP
CD74HC193M	-55 to 125	16 Ld SOIC
CD74HC193M96	-55 to 125	16 Ld SOIC
CD74HCT193E	-55 to 125	16 Ld PDIP

NOTE: When ordering, use the entire part number. The suffix 96 denotes tape and reel.

Functional Diagram



TRUTH TABLE

CLOCK UP	CLOCK DOWN	RESET	PARALLEL LOAD	FUNCTION
↑	H	L	H	Count Up
H	↑	L	H	Count Down
X	X	H	X	Reset
X	X	L	L	Load Preset Inputs

NOTE: H = High Voltage Level, L = Low Voltage Level, X = Don't Care, ↑ = Transition from Low to High Level

CD54/74HC192, CD54/74HC193, CD54/74HCT193

Absolute Maximum Ratings

DC Supply Voltage, V_{CC}	-0.5V to 7V
DC Input Diode Current, I_{IK}	
For $V_I < -0.5V$ or $V_I > V_{CC} + 0.5V$	$\pm 20mA$
DC Output Diode Current, I_{OK}	
For $V_O < -0.5V$ or $V_O > V_{CC} + 0.5V$	$\pm 20mA$
DC Output Source or Sink Current per Output Pin, I_O	
For $V_O > -0.5V$ or $V_O < V_{CC} + 0.5V$	$\pm 25mA$
DC V_{CC} or Ground Current, I_{CC} or I_{GND}	$\pm 50mA$

Thermal Information

Package Thermal Impedance, θ_{JA} (see Note 1):	
PDIP Package	67°C/W
SOIC Package	73°C/W
SOP Package	64°C/W
TSSOP Package	108°C/W
Maximum Junction Temperature	150°C
Maximum Storage Temperature Range	-65°C to 150°C
Maximum Lead Temperature (Soldering 10s)	300°C
(SOIC - Lead Tips Only)	

Operating Conditions

Temperature Range (T_A)	-55°C to 125°C
Supply Voltage Range, V_{CC}	
HC Types2V to 6V
HCT Types	4.5V to 5.5V
DC Input or Output Voltage, V_I , V_O	0V to V_{CC}
Input Rise and Fall Time	
2V	1000ns (Max)
4.5V	500ns (Max)
6V	400ns (Max)

CAUTION: Stresses above those listed in "Absolute Maximum Ratings" may cause permanent damage to the device. This is a stress only rating and operation of the device at these or any other conditions above those indicated in the operational sections of this specification is not implied.

NOTE:

- The package thermal impedance is calculated in accordance with JESD 51-7.

DC Electrical Specifications

PARAMETER	SYMBOL	TEST CONDITIONS			25°C			-40°C TO 85°C		-55°C TO 125°C		UNITS
		V_I (V)	I_O (mA)	V_{CC} (V)	MIN	TYP	MAX	MIN	MAX	MIN	MAX	
HC TYPES												
High Level Input Voltage	V_{IH}	-	-	2	1.5	-	-	1.5	-	1.5	-	V
				4.5	3.15	-	-	3.15	-	3.15	-	V
				6	4.2	-	-	4.2	-	4.2	-	V
Low Level Input Voltage	V_{IL}	-	-	2	-	-	0.5	-	0.5	-	0.5	V
				4.5	-	-	1.35	-	1.35	-	1.35	V
				6	-	-	1.8	-	1.8	-	1.8	V
High Level Output Voltage CMOS Loads	V_{OH}	V_{IH} or V_{IL}	-0.02	2	1.9	-	-	1.9	-	1.9	-	V
			-0.02	4.5	4.4	-	-	4.4	-	4.4	-	V
High Level Output Voltage TTL Loads	V_{OH}	V_{IH} or V_{IL}	-0.02	6	5.9	-	-	5.9	-	5.9	-	V
			-4	4.5	3.98	-	-	3.84	-	3.7	-	V
Low Level Output Voltage CMOS Loads	V_{OL}	V_{IH} or V_{IL}	0.02	2	-	-	0.1	-	0.1	-	0.1	V
			0.02	4.5	-	-	0.1	-	0.1	-	0.1	V
Low Level Output Voltage TTL Loads	V_{OL}	V_{IH} or V_{IL}	0.02	6	-	-	0.1	-	0.1	-	0.1	V
			4	4.5	-	-	0.26	-	0.33	-	0.4	V
Input Leakage Current	I_I	V_{CC} or GND	0.02	2	-	-	0.1	-	0.1	-	0.1	V
			5.2	6	-	-	0.26	-	0.33	-	0.4	V
Input Leakage Current	I_I	V_{CC} or GND	-	6	-	-	± 0.1	-	± 1	-	± 1	μA
Quiescent Device Current	I_{CC}	V_{CC} or GND	0	6	-	-	8	-	80	-	160	μA

CD54/74HC192, CD54/74HC193, CD54/74HCT193

DC Electrical Specifications (Continued)

PARAMETER	SYMBOL	TEST CONDITIONS			25°C			-40°C TO 85°C		-55°C TO 125°C		UNITS
		V _I (V)	I _O (mA)	V _{CC} (V)	MIN	TYP	MAX	MIN	MAX	MIN	MAX	
HCT TYPES												
High Level Input Voltage	V _{IH}	-	-	4.5 to 5.5	2	-	-	2	-	2	-	V
Low Level Input Voltage	V _{IL}	-	-	4.5 to 5.5	-	-	0.8	-	0.8	-	0.8	V
High Level Output Voltage CMOS Loads	V _{OH}	V _{IH} or V _{IL}	-0.02	4.5	4.4	-	-	4.4	-	4.4	-	V
High Level Output Voltage TTL Loads			-4	4.5	3.98	-	-	3.84	-	3.7	-	V
Low Level Output Voltage CMOS Loads	V _{OL}	V _{IH} or V _{IL}	0.02	4.5	-	-	0.1	-	0.1	-	0.1	V
Low Level Output Voltage TTL Loads			4	4.5	-	-	0.26	-	0.33	-	0.4	V
Input Leakage Current	I _I	V _{CC} to GND	-	5.5	-	-	±0.1	-	±1	-	±1	µA
Quiescent Device Current	I _{CC}	V _{CC} or GND	-	5.5	-	-	8	-	80	-	160	µA
Additional Quiescent Device Current Per Input Pin: 1 Unit Load (Note 2)	ΔI _{CC}	V _{CC} - 2.1	-	4.5 to 5.5	-	100	360	-	450	-	490	µA

NOTE:

- For dual-supply systems theoretical worst case (V_I = 2.4V, V_{CC} = 5.5V) specification is 1.8mA.

HCT Input Loading Table

INPUT	UNIT LOADS
P0-P3	0.4
MR	1.45
\overline{PL}	0.85
CPU, CPD	1.45

NOTE: Unit Load is ΔI_{CC} limit specified in DC Electrical Specifications table, e.g. 360µA max at 25°C.

CD54/74HC192, CD54/74HC193, CD54/74HCT193

Prerequisite For Switching Specifications

PARAMETER	SYMBOL	V _{CC} (V)	25°C			-40°C TO 85°C		-55°C TO 125°C		UNITS
			MIN	TYP	MAX	MIN	MAX	MIN	MAX	
HC TYPES										
Pulse Width CPU, CPD 192	t _W	2	115	-	-	145	-	175	-	ns
		4.5	23	-	-	29	-	35	-	ns
		6	20	-	-	25	-	30	-	ns
CPU, CPD 193	t _W	2	100	-	-	125	-	150	-	ns
		4.5	20	-	-	25	-	30	-	ns
		6	17	-	-	21	-	26	-	ns
\overline{PL}	t _W	2	80	-	-	100	-	120	-	ns
		4.5	16	-	-	20	-	24	-	ns
		6	14	-	-	17	-	20	-	ns
MR	t _W	2	100	-	-	125	-	150	-	ns
		4.5	20	-	-	25	-	30	-	ns
		6	17	-	-	21	-	26	-	ns
Set-up Time Pn to \overline{PL}	t _{SU}	2	80	-	-	100	-	120	-	ns
		4.5	16	-	-	20	-	24	-	ns
		6	14	-	-	17	-	20	-	ns
Hold Time Pn to \overline{PL}	t _H	2	0	-	-	0	-	0	-	ns
		4.5	0	-	-	0	-	0	-	ns
		6	0	-	-	0	-	0	-	ns
Hold Time CPD to CPU or CPU to CPD	t _H	2	80	-	-	100	-	120	-	ns
		4.5	16	-	-	20	-	24	-	ns
		6	14	-	-	17	-	20	-	ns
Recovery Time \overline{PL} to CPU, CPD	t _{REC}	2	80	-	-	100	-	120	-	ns
		4.5	16	-	-	20	-	24	-	ns
		6	14	-	-	17	-	20	-	ns
MR to CPU, CPD	t _{REC}	2	5	-	-	5	-	5	-	ns
		4.5	5	-	-	5	-	5	-	ns
		6	5	-	-	5	-	5	-	ns
Maximum Frequency CPU, CPD 192	f _{MAX}	2	5	-	-	4	-	3	-	MHz
		4.5	22	-	-	18	-	15	-	MHz
		6	24	-	-	21	-	18	-	MHz
CPU, CPD 193	f _{MAX}	2	5	-	-	4	-	3	-	MHz
		4.5	25	-	-	20	-	17	-	MHz
		6	29	-	-	24	-	20	-	MHz
HCT TYPES										
Pulse Width CPU, CPD 192	t _W	2	-	-	-	-	-	-	-	ns
		4.5	23	-	-	29	-	35	-	ns
		6	-	-	-	-	-	-	-	ns
CPU, CPD 193	t _W	2	-	-	-	-	-	-	-	ns
		4.5	23	-	-	29	-	35	-	ns
		6	-	-	-	-	-	-	-	ns

CD54/74HC192, CD54/74HC193, CD54/74HCT193

Prerequisite For Switching Specifications (Continued)

PARAMETER	SYMBOL	V _{CC} (V)	25°C			-40°C TO 85°C		-55°C TO 125°C		UNITS
			MIN	TYP	MAX	MIN	MAX	MIN	MAX	
\overline{PL}	t _W	2	-	-	-	-	-	-	-	ns
		4.5	16	-	-	20	-	24	-	ns
		6	-	-	-	-	-	-	-	ns
MR	t _W	2	-	-	-	-	-	-	-	ns
		4.5	20	-	-	25	-	30	-	ns
		6	-	-	-	-	-	-	-	ns
Set-up Time P _n to \overline{PL}	t _{SU}	2	-	-	-	-	-	-	-	ns
		4.5	15	-	-	19	-	22	-	ns
		6	-	-	-	-	-	-	-	ns
Hold Time P _n to \overline{PL}	t _H	2	-	-	-	-	-	-	-	ns
		4.5	0	-	-	0	-	0	-	ns
		6	-	-	-	-	-	-	-	ns
Hold Time CPD to CPU or CPU to CPD	t _H	2	-	-	-	-	-	-	-	ns
		4.5	16	-	-	20	-	24	-	ns
		6	-	-	-	-	-	-	-	ns
Recovery Time \overline{PL} to CPU, CPD	t _{REC}	2	-	-	-	-	-	-	-	ns
		4.5	15	-	-	19	-	22	-	ns
		6	-	-	-	-	-	-	-	ns
MR to CPU, CPD	t _{REC}	2	-	-	-	-	-	-	-	ns
		4.5	5	-	-	5	-	5	-	ns
		6	-	-	-	-	-	-	-	ns
Maximum Frequency CPU, CPD 192	f _{MAX}	2	-	-	-	-	-	-	-	MHz
		4.5	22	-	-	18	-	15	-	MHz
		6	-	-	-	-	-	-	-	MHz
CPU, CPD 193	f _{MAX}	2	-	-	-	-	-	-	-	MHz
		4.5	22	-	-	18	-	15	-	MHz
		6	-	-	-	-	-	-	-	MHz

Switching Specifications Input t_r, t_f = 6ns

PARAMETER	SYMBOL	TEST CONDITIONS	V _{CC} (V)	25°C			-40°C TO 85°C		-55°C TO 125°C		UNITS
				MIN	TYP	MAX	MIN	MAX	MIN	MAX	
HC TYPES											
Propagation Delay CPU to \overline{TCU}	t _{PLH} , t _{PHL}	C _L = 50pF	2	-	-	125	-	155	-	190	ns
		C _L = 50pF	4.5	-	-	25	-	31	-	38	ns
		C _L = 15pF	5	-	10	-	-	-	-	-	ns
		C _L = 50pF	6	-	-	21	-	26	-	32	ns
CPD to \overline{TCU}	t _{PLH} , t _{PHL}	C _L = 50pF	2	-	-	125	-	155	-	190	ns
		C _L = 50pF	4.5	-	-	25	-	31	-	38	ns
		C _L = 15pF	5	-	10	-	-	-	-	-	ns
		C _L = 50pF	6	-	-	21	-	26	-	32	ns
CPU to Q _n	t _{PLH} , t _{PHL}	C _L = 50pF	2	-	-	220	-	270	-	325	ns
		C _L = 50pF	4.5	-	-	43	-	54	-	65	ns
		C _L = 15pF	5	-	18	-	-	-	-	-	ns
		C _L = 50pF	6	-	-	37	-	46	-	55	ns

CD54/74HC192, CD54/74HC193, CD54/74HCT193

Switching Specifications Input $t_r, t_f = 6\text{ns}$ (Continued)

PARAMETER	SYMBOL	TEST CONDITIONS	V _{CC} (V)	25°C			-40°C TO 85°C		-55°C TO 125°C		UNITS
				MIN	TYP	MAX	MIN	MAX	MIN	MAX	
CPD to Q _n	t _{PLH} , t _{PHL}	C _L = 50pF	2	-	-	220	-	270	-	325	ns
		C _L = 50pF	4.5	-	-	43	-	54	-	65	ns
		C _L = 15pF	5	-	18	-	-	-	-	-	ns
		C _L = 50pF	6	-	-	37	-	46	-	55	ns
P _L to Q _n	t _{PLH} , t _{PHL}	C _L = 50pF	2	-	-	220	-	275	-	330	ns
		C _L = 50pF	4.5	-	-	44	-	55	-	66	ns
		C _L = 15pF	5	-	18	-	-	-	-	-	ns
		C _L = 50pF	6	-	-	37	-	47	-	56	ns
MR to Q _n	t _{PHL}	C _L = 50pF	2	-	-	200	-	250	-	300	ns
		C _L = 50pF	4.5	-	-	40	-	50	-	60	ns
		C _L = 15pF	5	-	17	-	-	-	-	-	ns
		C _L = 50pF	6	-	-	34	-	43	-	51	ns
Transition Time Q, TCU, TCD	t _{TLH} , t _{THL}	C _L = 50pF	2	-	-	75	-	95	-	110	ns
			4.5	-	-	15	-	19	-	22	ns
			6	-	-	13	-	16	-	19	ns
Input Capacitance	C _{IN}	C _L = 50pF	-	-	-	10	-	10	-	10	pF
Power Dissipation Capacitance (Notes 3, 4)	C _{PD}	C _L = 15pF	5	-	40	-	-	-	-	-	pF
HCT TYPES											
Propagation Delay CPU to TCU	t _{PLH} , t _{PHL}	C _L = 50pF	4.5	-	-	27	-	34	-	41	ns
		C _L = 15pF	5	-	11	-	-	-	-	-	ns
CPU to TCD	t _{PLH} , t _{PHL}	C _L = 50pF	4.5	-	-	27	-	34	-	41	ns
		C _L = 15pF	5	-	11	-	-	-	-	-	ns
CPU to Q _n	t _{PLH} , t _{PHL}	C _L = 50pF	4.5	-	-	40	-	50	-	60	ns
		C _L = 15pF	5	-	17	-	-	-	-	-	ns
CPD to Q _n	t _{PLH} , t _{PHL}	C _L = 50pF	4.5	-	-	40	-	50	-	60	ns
		C _L = 15pF	5	-	17	-	-	-	-	-	ns
P _L to Q _n	t _{PLH} , t _{PHL}	C _L = 50pF	4.5	-	-	46	-	58	-	69	ns
		C _L = 15pF	5	-	21	-	-	-	-	-	ns
MR to Q _n	t _{PHL}	C _L = 50pF	4.5	-	-	43	-	54	-	65	ns
		C _L = 15pF	5	-	18	-	-	-	-	-	ns
Transition Time Q, TCU, TCD	t _{TLH} , t _{THL}	C _L = 50pF	2	-	-	75	-	95	-	110	ns
			4.5	-	-	15	-	19	-	22	ns
Input Capacitance	C _{IN}	C _L = 50pF	-	-	-	10	-	10	-	10	pF
Power Dissipation Capacitance (Notes 3, 4)	C _{PD}	C _L = 15pF	5	-	50	-	-	-	-	-	pF

NOTES:

- C_{PD} is used to determine the dynamic power consumption, per gate.
- $P_D = V_{CC}^2 f_i + \sum (C_L V_{CC}^2)$ where f_i = Input Frequency, C_L = Output Load Capacitance, V_{CC} = Supply Voltage.

Test Circuits and Waveforms

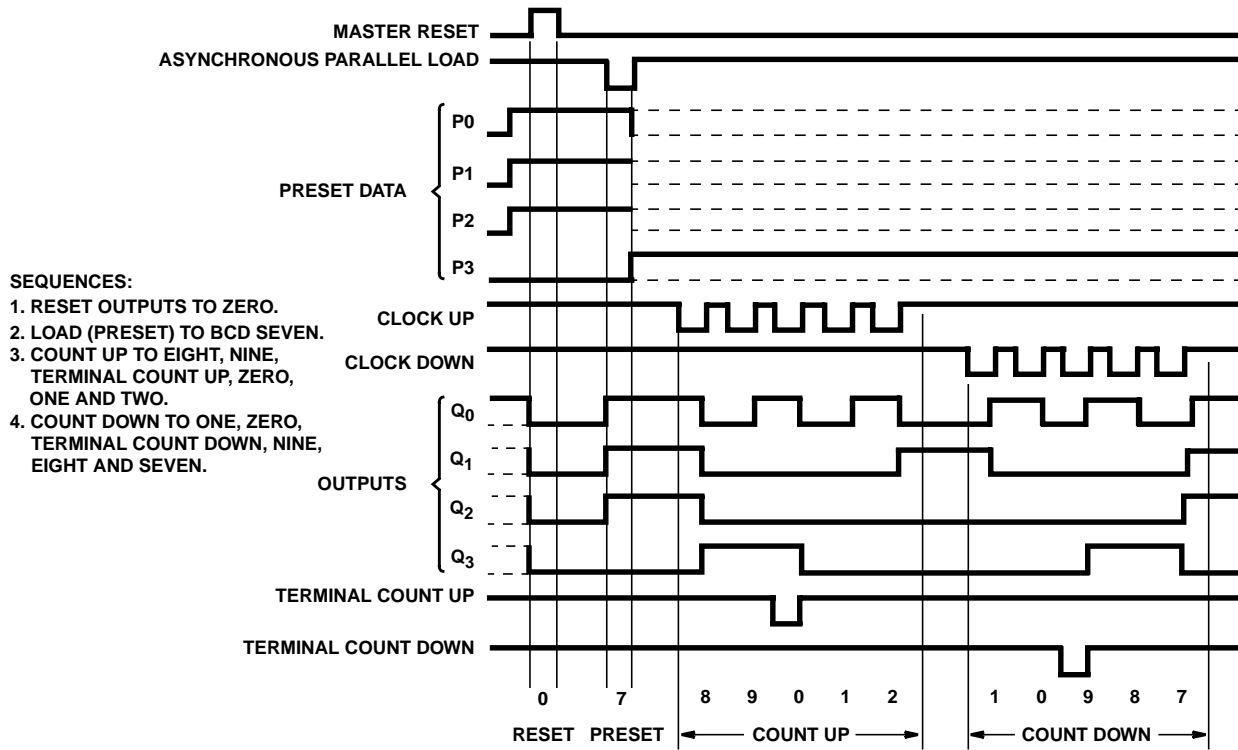

FIGURE 1. 'HC192 SYNCHRONOUS DECADE COUNTERS, TYPICAL RESET, PRESET AND COUNT SEQUENCES

Test Circuits and Waveforms (Continued)

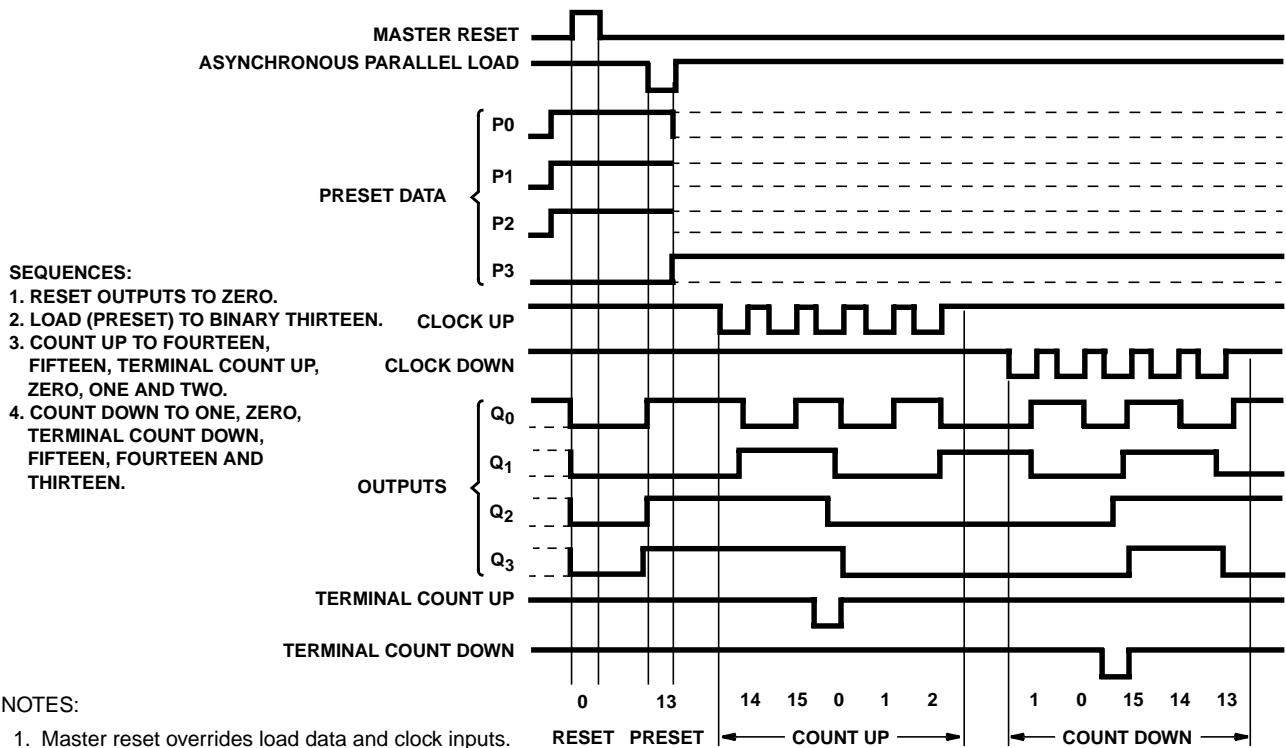

FIGURE 2. 'HC193 SYNCHRONOUS BINARY COUNTERS, TYPICAL RESET, PRESET AND COUNT SEQUENCES

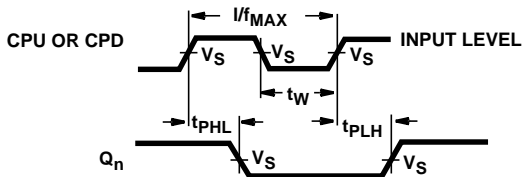

FIGURE 3. CLOCK TO OUTPUT DELAYS AND CLOCK PULSE WIDTH



FIGURE 4. CLOCK TO TERMINAL COUNT DELAYS

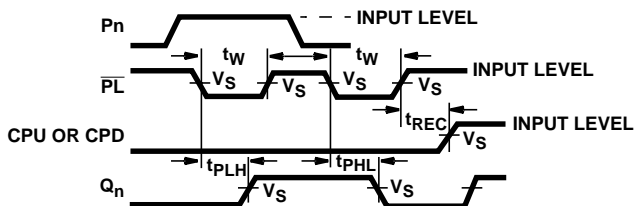

FIGURE 5. PARALLEL LOAD PULSE WIDTH, PARALLEL LOAD TO OUTPUT DELAYS, AND PARALLEL LOAD TO CLOCK RECOVERY TIME

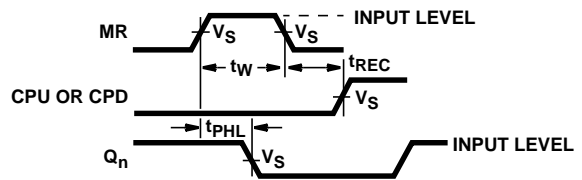

FIGURE 6. MASTER RESET PULSE WIDTH, MASTER RESET TO OUTPUT DELAY AND MASTER RESET TO CLOCK RECOVERY TIME

Test Circuits and Waveforms (Continued)

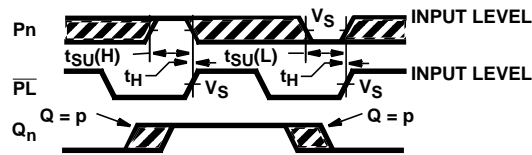

FIGURE 7. SET-UP AND HOLD TIMES DATA TO PARALLEL LOAD (PL)

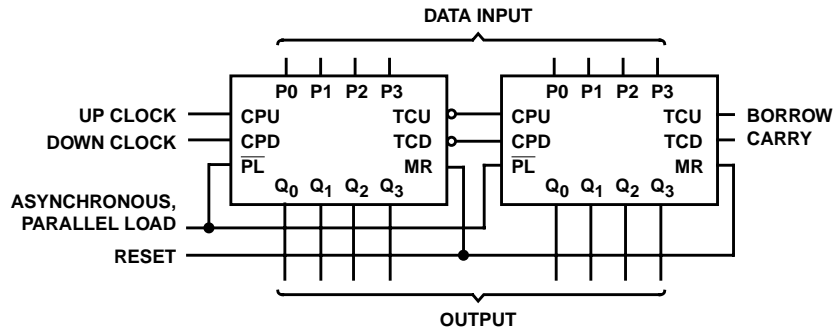

FIGURE 8. CASCADED UP/DOWN COUNTER WITH PARALLEL LOAD



NOTE: Illegal states in BCD counters corrected in one count.

NOTE: Illegal states in BCD counters corrected in one or two counts.

FIGURE 9. 'HC192, 'HCT193 STATE DIAGRAMS

J (R-GDIP-T**)

CERAMIC DUAL-IN-LINE

14 LEADS SHOWN

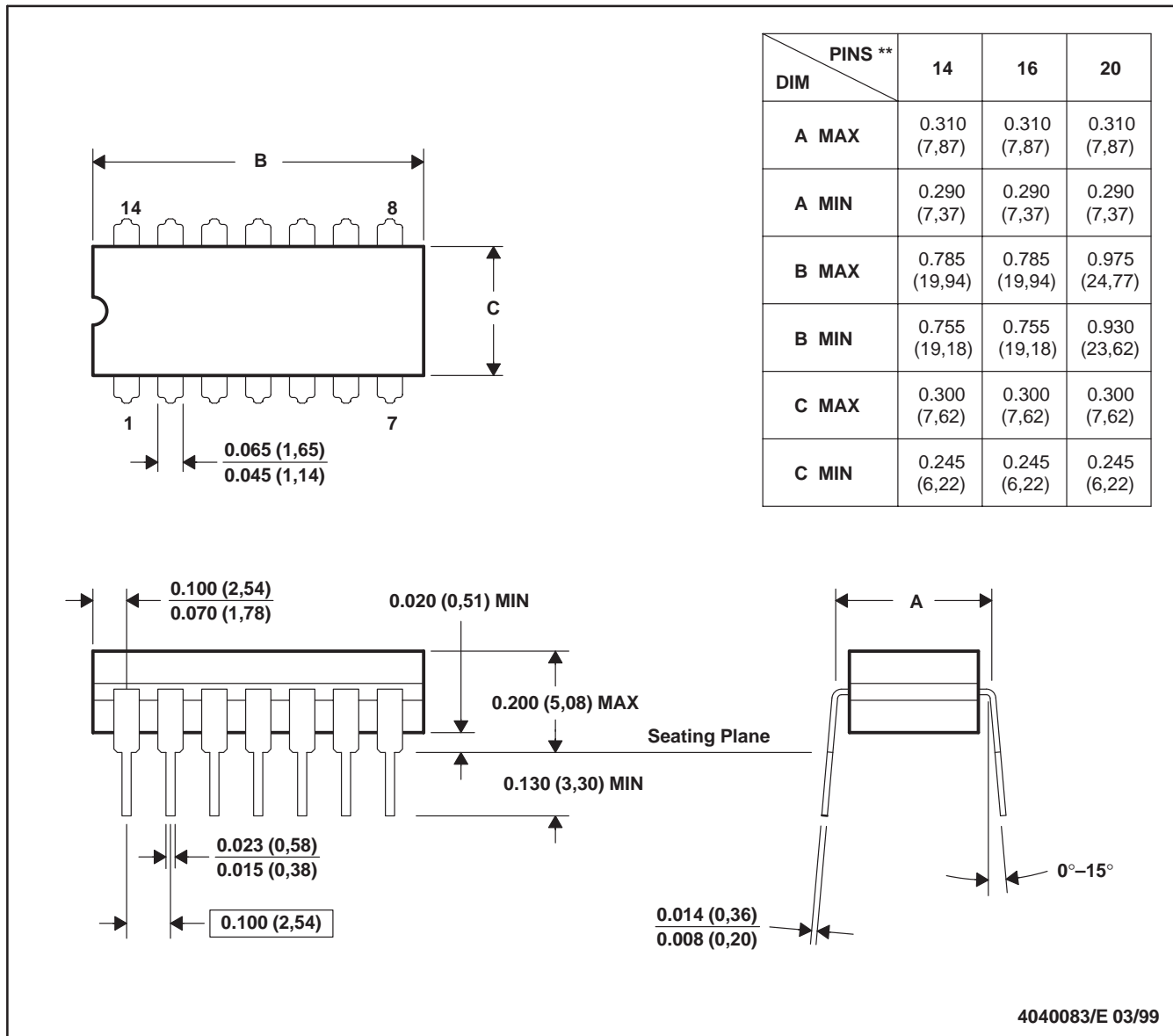

- NOTES: A. All linear dimensions are in inches (millimeters).
 B. This drawing is subject to change without notice.
 C. This package is hermetically sealed with a ceramic lid using glass frit.
 D. Index point is provided on cap for terminal identification.
 E. Falls within MIL STD 1835 GDIP1-T14, GDIP1-T16, and GDIP1-T20

N (R-PDIP-T**)

PLASTIC DUAL-IN-LINE PACKAGE

16 PINS SHOWN

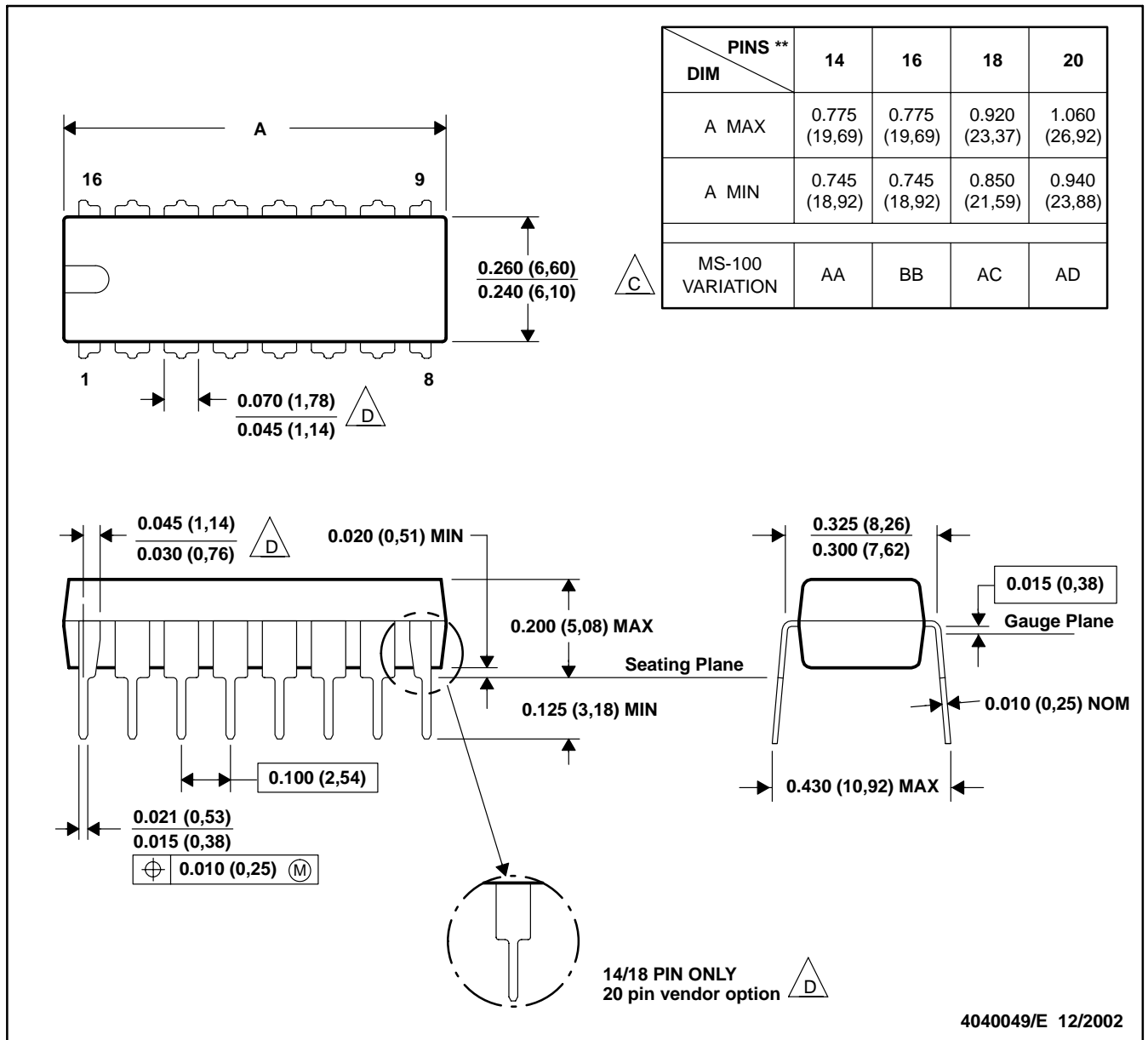

- NOTES: A. All linear dimensions are in inches (millimeters).
 B. This drawing is subject to change without notice.
 C Falls within JEDEC MS-001, except 18 and 20 pin minimum body length (Dim A).
 D The 20 pin end lead shoulder width is a vendor option, either half or full width.

D (R-PDSO-G**)

PLASTIC SMALL-OUTLINE PACKAGE

8 PINS SHOWN



4040047/E 09/01

- NOTES: A. All linear dimensions are in inches (millimeters).
 B. This drawing is subject to change without notice.
 C. Body dimensions do not include mold flash or protrusion, not to exceed 0.006 (0,15).
 D. Falls within JEDEC MS-012

NS (R-PDSO-G**)
 14-PIN SHOWN

PLASTIC SMALL-OUTLINE PACKAGE

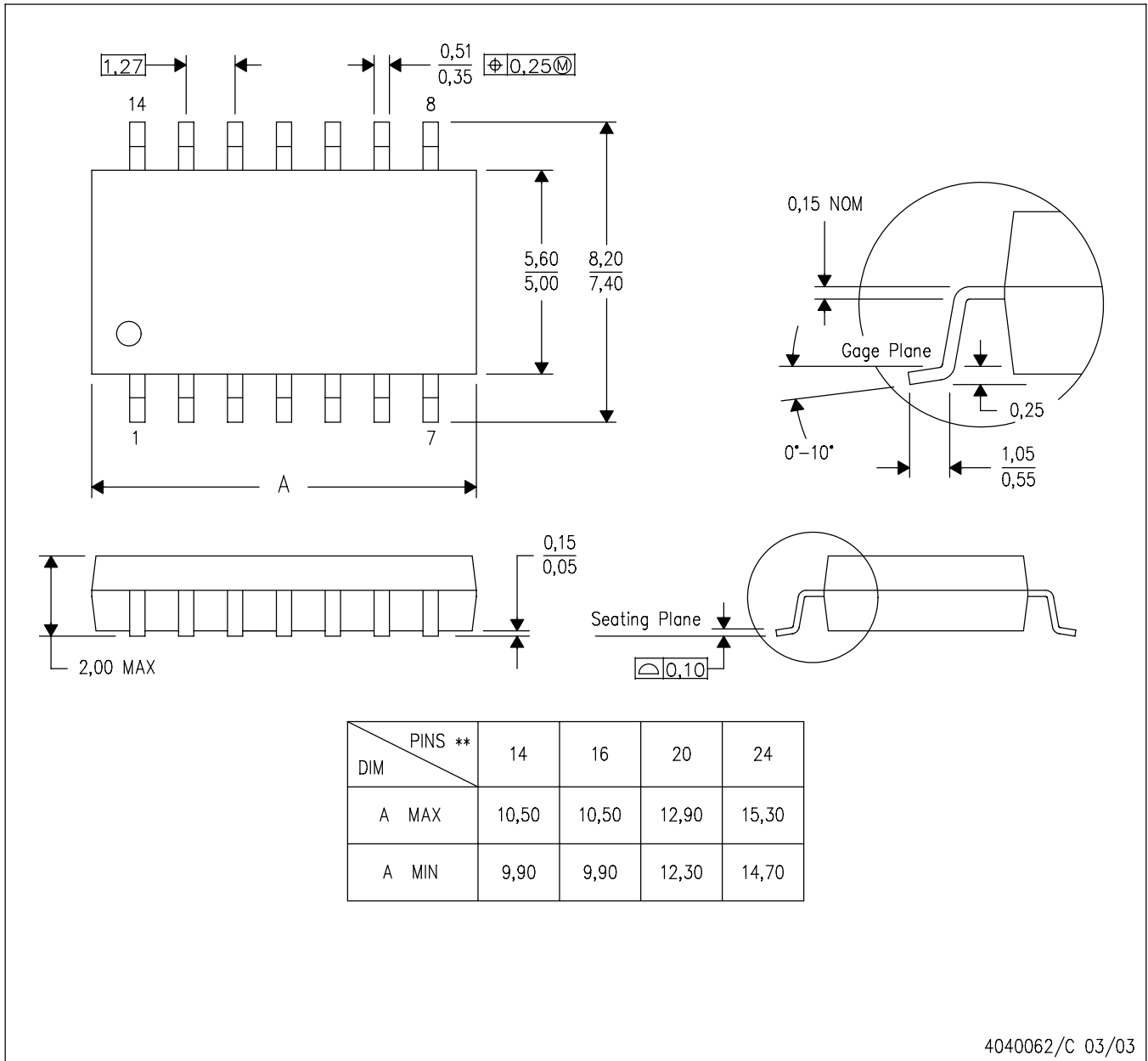

4040062/C 03/03

NOTES: A. All linear dimensions are in millimeters.
 B. This drawing is subject to change without notice.
 C. Body dimensions do not include mold flash or protrusion, not to exceed 0,15.

PW (R-PDSO-G**)

PLASTIC SMALL-OUTLINE PACKAGE

14 PINS SHOWN



4040064/F 01/97

- NOTES: A. All linear dimensions are in millimeters.
 B. This drawing is subject to change without notice.
 C. Body dimensions do not include mold flash or protrusion not to exceed 0,15.
 D. Falls within JEDEC MO-153

IMPORTANT NOTICE

Texas Instruments Incorporated and its subsidiaries (TI) reserve the right to make corrections, modifications, enhancements, improvements, and other changes to its products and services at any time and to discontinue any product or service without notice. Customers should obtain the latest relevant information before placing orders and should verify that such information is current and complete. All products are sold subject to TI's terms and conditions of sale supplied at the time of order acknowledgment.

TI warrants performance of its hardware products to the specifications applicable at the time of sale in accordance with TI's standard warranty. Testing and other quality control techniques are used to the extent TI deems necessary to support this warranty. Except where mandated by government requirements, testing of all parameters of each product is not necessarily performed.

TI assumes no liability for applications assistance or customer product design. Customers are responsible for their products and applications using TI components. To minimize the risks associated with customer products and applications, customers should provide adequate design and operating safeguards.

TI does not warrant or represent that any license, either express or implied, is granted under any TI patent right, copyright, mask work right, or other TI intellectual property right relating to any combination, machine, or process in which TI products or services are used. Information published by TI regarding third-party products or services does not constitute a license from TI to use such products or services or a warranty or endorsement thereof. Use of such information may require a license from a third party under the patents or other intellectual property of the third party, or a license from TI under the patents or other intellectual property of TI.

Reproduction of information in TI data books or data sheets is permissible only if reproduction is without alteration and is accompanied by all associated warranties, conditions, limitations, and notices. Reproduction of this information with alteration is an unfair and deceptive business practice. TI is not responsible or liable for such altered documentation.

Resale of TI products or services with statements different from or beyond the parameters stated by TI for that product or service voids all express and any implied warranties for the associated TI product or service and is an unfair and deceptive business practice. TI is not responsible or liable for any such statements.

Mailing Address:

Texas Instruments
Post Office Box 655303
Dallas, Texas 75265